



Translation of the  
Original Operating Instructions  
perma  
STAR CONTROL TIME

This operating manual is valid for the lubricator  
perma STAR CONTROL TIME in sizes S60, M120 and L250.

© 2006 perma-tec GmbH & Co. KG

Without the specific approval of perma-tec GmbH & Co. KG no part of this documentation can be copied or made available to third parties.

We have taken great care when compiling all the details contained in this documentation. However we cannot rule out discrepancies and we reserve the right to make technical changes to the product without giving advance notice.

We do not assume any judicial responsibility or liability for damages which may ensue as a result.

We will include any necessary changes in the next edition.

Compiled and printed: 08 / 01 / 2013

## Table of Contents

<b>1</b>	<b>VARIOUS</b>	<b>1</b>
1.1	About this operating manual	1
1.1.1	Terms used	1
1.1.2	Usage of safety instructions	1
1.1.3	Danger signs	1
1.1.4	Tips	1
1.2	Delivery	2
1.3	Lubricator perma STAR CONTROL TIME	2
1.3.1	Markings	2
1.3.2	Intended usage	2
1.4	Legal requirements	3
1.4.1	Liability	3
1.4.2	Warranty	3
<b>2</b>	<b>SAFETY INSTRUCTION</b>	<b>4</b>
2.1	Persons responsible for safety	4
2.2	General safety informations	4
2.3	Safety information for perma STAR CONTROL TIME	5
2.3.1	Safety during installation and maintenance	5
2.3.2	Safety when handling LC units	5
<b>3</b>	<b>TECHNICAL DATA</b>	<b>6</b>
3.1	Data sheet: power supply	6
3.1.1	Cable construction	6
3.1.2	Values	6
3.2	Product specifications	6
3.2.1	Pin assignment	6
3.2.2	Components	7
3.2.3	Airborne noise emission	7
3.2.4	Function	8
3.2.5	Reference table for discharge amount per discharge cycle	8
3.3	Weights and measurements	8
3.4	Operating conditions	9
3.4.1	Temperatures	9
3.4.2	Ambient conditions	9
<b>4</b>	<b>STORAGE</b>	<b>9</b>
4.1	General storage information	9
4.1.1	Storage conditions	9
4.1.2	Storage periods	9

<b>5</b>	<b>STARTING AND OPERATING</b>	<b>10</b>
5.1	Preparation	10
5.2	Before operation	10
5.3	Initial operation	10
5.4	During operation	11
<b>6</b>	<b>CHANGING THE LC UNIT</b>	<b>12</b>
6.1	General note	12
6.2	How to change the LC unit	12
<b>7</b>	<b>DRIVE UNIT SETTINGS</b>	<b>13</b>
7.1	Function display	13
7.2	Circuit board settings	13
7.2.1	Setting discharge amount	14
7.2.2	Setting volume of LC unit	14
7.3	Table of discharge	14
7.3.1	Examples for determining proper dip switch settings to achieve optimal lubrication	15
7.3.2	Changing the discharge volume after the perma STAR CONTROL TIME has been in operation/reset function	17
<b>8</b>	<b>TROUBLE SHOOTING</b>	<b>18</b>
<b>9</b>	<b>DISPOSAL</b>	<b>19</b>
<b>10</b>	<b>ACCESSORIES FOR perma STAR CONTROL IMPULSE</b>	<b>19</b>
10.1	Accessories	19
10.2	Replacement parts	19
<b>11</b>	<b>SERVICE</b>	<b>19</b>
<b>12</b>	<b>SUGGESTION FOR PLC CONNECTION</b>	<b>20</b>
12.1	Suggestion for PLC connection with one output signal	20
12.2	Suggestion for PLC connection with two output signals	21
12.3	Suggestion for PLC connection with three output signals	22

**EC Declaration of Conformity**

# 1 VARIOUS

## 1.1 About this operating manual

- ◆ This operating manual is intended for the safe operation of the perma STAR CONTROL TIME automatic lubricator. It contains safety instructions which must be adhered to.
- ◆ Everyone who works on or with the lubricator must have access to this operating manual during their shift. They must also pay attention to all relevant instructions and notices.
- ◆ The operating manual must be kept in a complete and easy to read condition.

### 1.1.1 Terms used

#### ◆ Lubricator

In the following text, the “lubricator” will either be called “lubricator” or by its name “perma STAR CONTROL TIME”.

#### ◆ Lubrication Canister

In the following text, the “Lubrication Canister” will be called LC unit.  
The user can order the LC unit filled with different oils and greases and in sizes S60, M120 and L250.

### 1.1.2 Usage of safety instructions

All safety instructions in this operating manual are standardized.

### 1.1.3 Danger signs



Attention Danger!

This sign warns you of any danger to people's health, life-threatening injuries and death.

### 1.1.4 Tips



This sign alerts you to application tips which will help you in doing certain things quicker and safer.

## 1.2 Delivery

- ◆ perma STAR CONTROL TIME can be ordered and delivered according to customer specifications in regards to type of grease and oil, size / content of LC unit.
- ◆ Upon delivery, make sure to check if the delivered goods correspond to your order. perma-tec GmbH & Co. KG will not accept liability for subsequent claims of any shortcomings.
- ◆ Please immediately forward any claim
  - of noticeable transport damage: directly to the forwarder
  - of noticeable faults, shortcomings or defects: directly to your perma distributor.

## 1.3 Lubricator perma STAR CONTROL TIME

### 1.3.1 Markings

- ◆ The lubricator perma STAR CONTROL TIME is clearly marked with a label on the drive system and a label on the LC unit.
- ◆ **CE Mark** on the drive unit
- ◆ Manufacturer:

perma-tec GmbH & Co. KG  
Hammelburger Straße 21  
97717 Euerdorf, Germany  
Tel: +49 (0) 9704 609-0  
Fax: +49 (0) 9704 609-50

E-mail: [info@perma-tec.com](mailto:info@perma-tec.com)  
Homepage: [www.perma-tec.com](http://www.perma-tec.com)

### 1.3.2 Intended Usage

- ◆ The lubricator perma STAR CONTROL TIME
  - supplies all lubrication points with oil and grease to a large extent continuously, precisely and temperature independent up to a pressure build-up of max **5 bar / 75 psi**; can be turned off and on via the machine (machine controlled).
  - can be used for all lubrication points of sliding- and roller bearings, drive- and transport chains, sliding guideways, open gears and seals.
  - is intended for use on machinery and equipment where lubrication is only to take place when the machine is running, and where a status report to the machine is desired.
  - is only to be used for the ordered purpose and purposes confirmed by perma-tec.

- is only to be used for operating conditions recommended in this operating manual.
- is only to be used with settings and variations recommended by this operating manual.



**Any other usage, setting and variation is considered to be inappropriate.**

## 1.4 Legal requirements

### 1.4.1 Liability

- ◆ The information, data and tips stated in this operating manual were up-to-date as of the printing date.  
No claims for already delivered lubricators can be made based on the information, pictures and descriptions.
- ◆ perma-tec GmbH & Co. KG can not be held liable for damages and malfunctions caused by:
  - inappropriate usage;
  - unauthorized alterations to the drive system or the LC unit;
  - inappropriate operations on or with the lubricator;
  - incorrect operation and settings of the lubricator;
  - incorrect settings of time and size of the lubricator;
  - ignoring the operating manual.

### 1.4.2 Warranty

- ◆ Warranty terms and conditions: see terms and conditions of sale and delivery appertaining to perma-tec GmbH & Co. KG.
- ◆ Lodge any warranty claims with perma-tec immediately after the defect or error has been identified.
- ◆ The warranty expires in all instances where no liability claims can be enforced.

## 2 SAFETY INSTRUCTION

### 2.1 Persons responsible for safety

#### ◆ Operator

- The operator is any individual or legal entity who or which uses the lubricator or on whose authority the lubricator is used.
- The operator or his safety officer must warrant,
  - that all the relevant regulations, instructions and laws are adhered to;
  - that only qualified personnel will work with and on the lubricator;
  - that the operating manual is made available to the personnel for all work done with and on the lubricator, and that the personnel adhere to it;
  - that unauthorized personnel are not allowed to work with and on the lubricator;
  - and that the safety regulations are adhered to when mounting the lubricator or during maintenance.

#### ◆ Qualified personnel

Qualified personnel are persons who, by virtue of their training, experience, instruction and information concerning the relevant standards and provisions, accident prevention regulations and plant and operating conditions, as received from the person responsible for the safety of the plant, are entitled to carry out the activities required at any time so that any possible dangers or hazards can be identified and avoided.

### 2.2 General safety instructions

- ◆ We are not laying claim to completeness as regards these safety instructions. Please contact your local supplier if you have any queries or problems.
- ◆ At the time of delivery the lubricator is in line with state-of-the-art technology and in principle is considered to be safe to operate.
- ◆ Dangers emanate from the lubricator for persons, the lubricator itself and for other material assets of the operator if:
  - unqualified personnel operates the lubricator;
  - the lubricator is used inappropriately and for operations that it was not intended to be used for;
  - the lubricator setting / variation is incorrect.



- ◆ The lubricators must be filled with the correct oil or grease and must be set to operate correctly without causing any hazards to people when set, installed, and used for its intended purpose. This also pertains to their operation together with the complete machine and its lubrication points.
- ◆ Make sure to prevent material damage by putting certain measures in place in the case that the lubricator malfunctions.
- ◆ Operate the lubricator only when it is in perfect condition.
- ◆ Retrofitting, changing or reconstructing the lubricator is not allowed. perma-tec must be consulted first.
- ◆ The LC unit should not be forced open.

## 2.3 Safety information for perma STAR CONTROL TIME

### 2.3.1 Safety during installation and maintenance



- ◆ Ensure that all workstations and traffic routes are clean and safe!
- ◆ Ensure that the relevant regulations and guidelines are adhered to when the installation or maintenance work is carried out in places where danger of falling exists.
- ◆ Ensure that the relevant safety and operating instructions are observed when the lubricators are installed on machines or in factories (i.e. to stop the machine).

### 2.3.2 Safety when handling the LC unit



- ◆ Avoid contact of oil and grease with eyes, skin, and clothing!
- ◆ Avoid swallowing of oil and grease!
- ◆ Prevent oil and grease from getting into soil or sewer system!
- ◆ Observe safety data sheets of oils and greases! You may also download data sheets of lubricants supplied by perma-tec from perma-tec's web page ([www.perma-tec.com](http://www.perma-tec.com)) or ask your local supplier.
- ◆ Oil and grease on traffic ways will increase the danger of slipping! Therefore, immediately clean oil and grease from floors!
- ◆ Only use original LC units from perma-tec!

### 3 TECHNICAL DATA

#### 3.1 Data sheet: power supply

##### 3.1.1 Cable construction:

Conductor cross-sectional dimensions:	4 x 0.25 mm <sup>2</sup>
Flexible cord construction:	Cu flex 32 x Ø 0.1 mm blk
Insulation:	PVC Ø 1.3 + 0.05 wall thickness abt. 0.32 mm
Cable covering:	PUR / black

##### 3.1.2 Values

Line resistance:	79.9 Ω/km at 20 °C (68 °F)
Safe temperature:	static condition: -25 to +70 °C (-13 to 158 °F) dynamic condition: -5 to +70 °C (23 to 158 °F)
Output load	each max. 400 mA, short-circuit proof



**Cable is drag chain qualified, approved for the smallest bending radius 60 mm.**



**Power supply 15 to 25 V DC (max. 30 V DC, 5 % residual ripple) must be applied for at least 2 minutes in order to achieve the correct discharge period! Typical current consumption 0.2 A (current at make can be up to 1.2 A). Max. output load (Pin 2 + 4) cannot exceed 400 mA each.**

#### 3.2 Product specifications

##### 3.2.1 Pin assignment

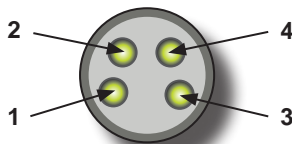

Pin assignment of the connector on the lubricator

Pin assignment	cable colour	signal
1	brown	current +
2	white	LED green digital
3	blue	current -
4	black	LED red digital

### 3.2.2 Components

- ◆ Lubricators are delivered as requested by the customer in regards to size, and oil or grease filling. They consist of (see Picture 1):
  - a) Plug
  - b) LC unit (Lubrication Canister), available with the requested lubricant and in three different sizes (thread size R1/4).  
**LC unit cannot be refilled!**
  - c) Drive unit, consisting of a gear motor and circuit board for control of the lubricator. Every drive has an individual, consecutive series number (this number must be provided for all inquiries about the system).  
**Drive unit can be re-used.**
  - d) LED function display
  - e) Cover (re-usable)
  - f) Cable with plug (re-usable)

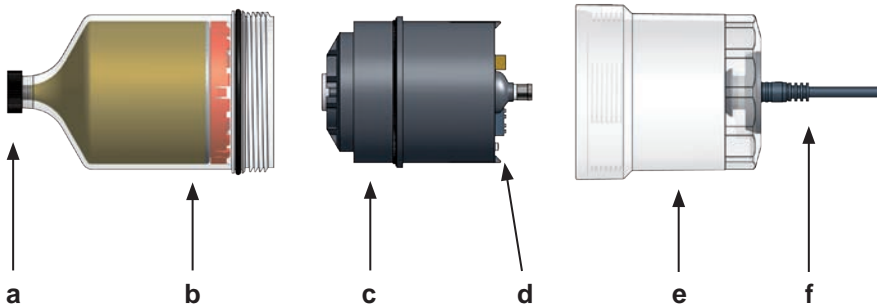

Pict. 1

### 3.2.3 Airborne noise emission

Emission sound pressure level of the lubrication system: < 70 dB(A)  
(Measuring point: distance 1 m / height 1.6 m)

### 3.2.4 Function

Whenever external power is applied, the lubricator discharges a set amount of lubricant in pre-determined intervals.

In the LC unit, a motor driven spindle pushes the lubricant out of the LC unit. The piston will move and, depending on the counter pressure, will build up pressure in the LC unit of up to **5 bar** (75 psi). The automatic pressure shut off will turn the system OFF after several attempts when the pressure exceeds 5 bar.

With dip switch 3 and 4 of the 4-way code switch on the circuit board (marked "VOL") you can set the size of the LC unit. With dip switch 1 and 2 (marked "TIME") you can set the discharge amount for every 100 operating hours.

perma STAR CONTROL TIME divides the set discharge amount (= size of the LC unit) into several small discharge cycles within the discharge period (please see the following chart listing discharge amount per discharge cycle. Please also refer to chapt. 7.3).

### 3.2.5 Reference table for discharge amount per discharge cycle

Discharge period	Pause time	Discharge amount per discharge cycle		
		S60	M120	L250
[Months]	[h:min]	[cm <sup>3</sup> ]	[cm <sup>3</sup> ]	[cm <sup>3</sup> ]
1	1:30	0.13	0.26	0.53
3	4:37			
6	9:17			
12	18:36			

### 3.3 Weights and measurements

Type	Volume [cm <sup>3</sup> ]	Diameter D [mm]	Total length L [mm]	Weight empty [kg]	Weight filled with SF01 [kg]
S60	60	71	142	0.344	≈ 0.400
M120	120	71	165	0.358	≈ 0.470
L250	250	71	215	0.399	≈ 0.632

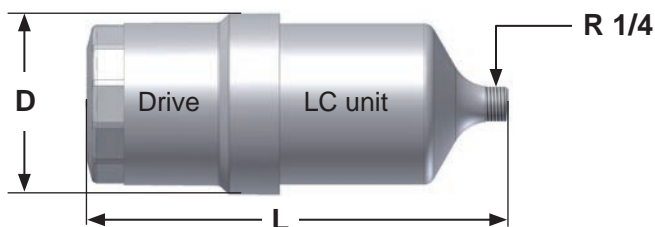

### 3.4 Operating conditions

#### 3.4.1 Temperatures

- ◆ Temperature range: -10 °C to +50 °C (+14 °F to +122 °F)
- ◆ Within this temperature range, a regular discharge and a max. output pressure up to 5 bar (75 psi) is guaranteed.
- ◆ For temperatures higher than +50 °C (+122 °F) and lower than -10 °C (+14 °F), the correct function can no longer be guaranteed.

#### 3.3.2 Ambient conditions

- ◆ The lubricators are protected against dust and water jets when the individual parts are assembled correctly.
- ◆ Ambient media, especially chemically aggressive substances, may affect sealing rings and plastic materials.

## 4 STORAGE

### 4.1 General storage information

When the lubricators are not immediately installed, you must ensure appropriate storage conditions in dry, dust free, sunlight-protected rooms indoors.

#### 4.1.1 Storage conditions

- ◆ Dry
- ◆ Dust free
- ◆ Temperature  $+20\text{ °C} \pm 5\text{ °C}$  ( $+68\text{ °F} \pm 9\text{ °F}$ )

#### 4.1.2 Storage periods

- ◆ Up to one year
  - LC unit: refer to filling date i. e. 03/06 = June 2003
  
- ◆ Up to two years
  - Drive unit
  - Drive unit cover
  - Cable and plug

## 5 STARTING AND OPERATING

### 5.1 Preparation



Before installing the lubricator, the lubrication points and any extensions must be adequately pre-lubricated with the same lubricant which is contained in the perma STAR CONTROL TIME.

For this purpose, perma-tec offers a 400 g lubricant cartridge for grease guns (see chapter 10.1).

- ◆ Please use a STAR support flange G1/4o x G1/4i (brass/plastic) from perma-tec for the installation of perma STAR CONTROL TIME.
- ◆ For horizontal mounting positions we recommend the clip (plastic) to hold the lubricator in place.

The perma STAR installation instructions provide support for mounting of the lubricators and can be downloaded from our homepage.

### 5.2 Before operation

- ◆ Completely check the lubricator for visible damages!
- ◆ Check if the LC unit is filled with the requested grease or oil!
- ◆ Do “VOL” switches 3+4 of the four-way code switch in the drive unit match the correct size of the LC unit (see chapter 7.3)?
- ◆ Do “TIME” switches 1+2 of the four-way code switch in the drive unit match the desired discharge period (see chapter 7.3)?
- ◆ Oil-filled LC units: Check if an oil retaining valve is attached.
- ◆ Were all components properly assembled and screwed together hand-tight?
- ◆ Ensure that the cable is plugged into the perma STAR CONTROL TIME.

### 5.3 Initial operation

- ◆ perma STAR CONTROL TIME is delivered with a pre-set discharge period of 6 months and LC unit M120 (standard setting).
- ◆ On request, we can pre-set the discharge amount or discharge mode according to your requirements.



**Regardless of which option you choose, the operator must check the setting again and carry out any desired changes before starting the lubricator (see chapter 7)!**

- ◆ Pre-lubricate the lubrication point with the same lubricant that is contained in the perma STAR CONTROL TIME (see chapter 5.1).
- ◆ Check if the thread of the LC unit corresponds to the thread of the screw point (R1/4).
- ◆ In the switch cabinet, connect the cable according to the PLC-wiring diagram for the status display. The connection may only be carried out by qualified experts and must be carried out according to local standards (i. e. IEC, VDE etc.).



**NOTE: Incorrect connection of the perma STAR CONTROL TIME could destroy the electronics.**

- ◆ Unscrew and remove the cover of the drive unit. Set the dip switches 1-4 (“TIME” and “VOL”) of the 4-way code switch according to your calculations (see chapter 7.3). Place cover back on drive unit and remove the plug from the LC unit. Screw perma STAR CONTROL TIME onto the lubrication point (handtight). Never screw in the lubricator a second time as this would impair the self-sealing of the thread. Plug the cable into the connection on perma STAR CONTROL TIME.
- ◆ Seal threads of all connecting parts with a suitable, standard sealant. Ensure that oil filled lubricators are mounted (max.  $\pm 45^\circ$ ) vertically (outlet pointing down).

**NOTE: After a reset, perma STAR CONTROL TIME will start with the corresponding pause time.**

#### 5.4 During operation

- ◆ Carry out regular performance checks during operation.  
Check for possible leakages and the status of the lubricator!
- ◆ Regularly monitor the fill-level of the transparent LC unit!
- ◆ In case of malfunctions during operation, please check the trouble shooting chart in chapter 8. If the malfunction cannot be corrected, please contact your perma distributor.



**Please make sure to refer to point 7.3.2 if the settings must be changed after the perma STAR CONTROL TIME was already put into operation.**

## 6 CHANGING THE LC UNIT

### 6.1 General note

When the red and the green LED light up at the same time, the LC unit is empty and should be replaced.

During the LC unit exchange, it is possible to choose a different size and a different discharge period by resetting the dip switches of the 4-way code switch on the circuit board.

Since the drive unit and the circuit board must always be protected from moisture, the exchange must be carried out in a dry place!

### 6.2 How to change the LC unit

- a) Unplug the cable from the perma STAR CONTROL TIME.
- b) Completely screw off and remove the lubricator from the lubrication point.
- c) Unscrew the cover from the drive unit.
- d) Remove the drive unit from the LC unit.
- e) Dip switches of the 4-way code switch should be changed in cases where a different size LC unit was used, or if a different discharge period is desired (see chapter 7.3.2).
- f) Place drive unit on top of new LC unit until the teeth of both units are locked.
- g) Screw the cover of the drive unit onto the LC unit hand-tight.
- h) Remove plug from the LC unit.
- i) Screw the lubricator into the lubrication point hand-tight, but DO NOT screw it in a second time.
- j) For oil filled lubricators, make sure that the lubricator is installed (max.  $\pm 45^\circ$ ) vertically (outlet pointing down).
- k) Plug cable back into the perma STAR CONTROL TIME.
- l) After a reset/exchange of LC unit, perma STAR CONTROL TIME will start with the corresponding pause time.

**Please note that the warranty will expire if above instructions are not followed.**



## 7 DRIVE UNIT SETTINGS

### 7.1 Function display

The LEDs (Light Emitting Diodes) are on the circuit board and are visible through the transparent cover (see picture 2, chapter 7.2).

The perma STAR CONTROL TIME has a red and green LED. The following signals about operating conditions/malfunctions are displayed by the LED for the user:

LED	Signal	Meaning
green	steady	System functions OK
red	steady for less than 30 seconds with motor run	STAR CONTROL TIME is discharging
red	steady signal for more than 30 seconds	Malfunction/Error
green and red	steady signal	LC unit empty, please change

### 7.2 Circuit board settings

The 4-way code switch is located on the circuit board.

Dip switches 1+2 marked "TIME" are used to set the discharge amount, dip switches 3+4 marked "VOL" are used to set the LC unit size.

You may set/change the switches with the help of a small screw driver or with your fingers.

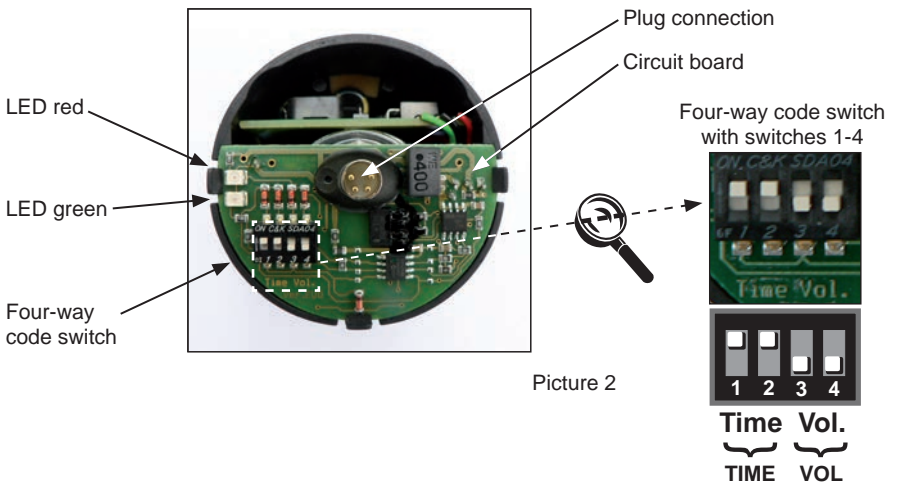

### 7.2.1 Setting the discharge amount

The lubricant amount per impulse must be set with dip switches 1+2 “TIME” of the 4-way code switch located on the circuit board of the drive unit.



If the position of code switches 1+2 “TIME” of the 4-way code switch does not correspond to the desired discharge amount (see chapter 7.3), it will lead to wrong signals and to over- or under-lubrication (see chapter 8).

### 7.2.2 Setting volume of LC units







The LC unit size must be set with dip switches 3+4 “VOL” of the 4-way code switch located on the circuit board of the drive unit.



If the position of code switches 3+4 “VOL” of the 4-way code switch does not correspond to the actual size of the LC unit, it will lead to an incorrect signalling of fill level (see chapter 8).

### 7.3 Table of discharge

**Amount of discharge in cm<sup>3</sup> (1 cm<sup>3</sup> ≈ 0.9 g Lubricant) per 100 operating hours**

Code switch LC unit	 Vol. S60	 Vol. M120	 Vol. L250	Dip switches 3+4 “VOL” of the 4-way code switch  Discharge period
 Time	8.33	16.67	34.72	△ 1 Month at continuous operation
 Time	2.78	5.56	11.57	△ 3 Months at continuous operation
 Time	1.39	2.78	5.79	△ 6 Months at continuous operation
 Time	0.69	1.39	2.89	△ 12 Months at continuous operation

Dip switches 1+2  
“TIME” of the  
4-way code switch

### 7.3.1 Examples for determining proper dip switch settings to achieve optimal lubrication

In the “normal mode” (per 100 operating hours)

#### Example 1:

A roller bearing is to be provided with  $14 \text{ cm}^3$  of lubricant every 500 hours of operation:  $14 \text{ cm}^3 \div 500 \text{ h} = 0.028 \text{ cm}^3 \text{ per h} = \underline{2.8 \text{ cm}^3 \text{ per 100 h}}$

The discharge table in chapt. 7.3 on page 14 shows that 3 different settings are possible for each LC unit size

#### Variation I:

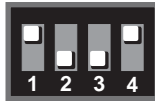

#### Time Vol.

2.78  $\text{cm}^3/100 \text{ h}$  for a  $60 \text{ cm}^3$  LC unit (S60)

#### Variation II:



#### Time Vol.

2.78  $\text{cm}^3/100 \text{ h}$  for a  $120 \text{ cm}^3$  LC unit (M120)

#### Variation III:

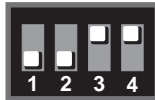

#### Time Vol.

2.89  $\text{cm}^3/100 \text{ h}$  for a  $250 \text{ cm}^3$  LC unit (L250)

At this point, you can calculate the total discharge life of the LC unit (and the exchange date). Proceed as following:

The roller bearing to be lubricated is installed in a machine which runs 5 days per week 8 hours per working day.

**To Variation I:**  $60 \text{ cm}^3$  LC unit (S60)

- $2.78 \text{ cm}^3/100 \text{ h} = 0.0278 \text{ cm}^3/\text{h}$
- $60 \text{ cm}^3 : 0.0278 \text{ cm}^3/\text{h} = 2158.3 \text{ h}$
- $2158.3 \text{ h} : 40 \text{ h/week} = 54 \text{ weeks}$

The lubricant is sufficient for more than 1 year, not including additional operational breaks or any other machine standstills.

- To Variation II:** 120 cm<sup>3</sup> LC unit (M120)
- 2.78 cm<sup>3</sup>/100 h = 0.0278 cm<sup>3</sup>/h
  - 120 cm<sup>3</sup> : 0.0278 cm<sup>3</sup>/h = 4316.5 h
  - 4316.5 h : 40 h/week = 108 weeks

The lubricant is sufficient for more than 2 years, not including additional operational breaks or any other machine standstills.

- To Variation III:** 250 cm<sup>3</sup> LC unit (L250)
- 2.89 cm<sup>3</sup>/100 h = 0.0289 cm<sup>3</sup>/h
  - 250 cm<sup>3</sup> : 0.0289 cm<sup>3</sup>/h = 8650.5 h
  - 8650.5 h : 40 h/week = 216 weeks

The lubricant is sufficient for more than 4 years.

**Due to the stability of each individual lubricant we recommend variation I with a 60 cm<sup>3</sup> LC unit.**

### Example 2:

Given the same machine as in example 1, but with different and irregular running times e.g. 4 hours on day one, 1.5 hours on day two, not running on days three and four, and 3 hours on day five.

You can determine the dip switch setting as in example number 1, but the total discharge life of the LC unit and exchange date cannot be determined.



It is possible to calculate discharge periods of several years. Particular attention should be paid to these lubrication points. Monitoring is possible with PLC connection via the output signal "End of discharge". Please pay special attention to the shelf life of the grease when you choose long lubrication periods.

### 7.3.2 Changing the discharge volume after the perma STAR CONTROL TIME has been in operation/reset function

With the reset-function, the lubricator can be returned to its initial state by resetting the internally saved parameters.

- a) Unplug the power plug from the lubricator.
- b) Unscrew the lubricator from the lubrication point.
- c) Unscrew the LC unit from the drive unit.
- d) Put dip switches 3+4 "VOL" of the 4-way code switch to this position (Reset). → 
- e) Attach the power connector to the drive unit.
- f) As soon as the motor has run for 2 sec, both LED's will light up. Pull the plug from the drive unit.
- g) Set dip switches "TIME" and "VOL" of the 4-way code switch according to chapter 7.3.
- h) Again, push and hold the white peg on the bottom of the drive unit (see picture below).
- i) Attach the power connector to the drive unit.
- j) After 3 seconds, release the peg and unplug the power connector.
- k) Mount the drive as described under point 6.2.

**NOTE: Changing the discharge volume as described above may result in an incorrect LED display of "LC unit empty" which depends on how empty the attached LC unit was before the discharge volume was changed. Therefore it is important that you manually monitor the End of discharge period.**



## 8 TROUBLE SHOOTING

In case of malfunctions during operation, please check the following chart for possible causes and corrective actions. If the malfunction is not listed, please contact your perma distributor.

Malfunctions	Possible cause	Solution
perma STAR CONTROL TIME does not function	<ul style="list-style-type: none"> <li>- Wrong cable connection</li> <li>- Break in cable</li> <li>- No power supply</li> <li>- Relay defect in machine</li> </ul>	<p>Connect cable according to pin assignment. Check pin assignment</p> <p>Check voltage at plug, attach new cable</p> <p>Check power supply. Too many perma STAR CONTROL TIME attached for power supply used.</p> <p>Change relays</p>
perma STAR CONTROL TIME signals "system functions OK" (green LED), although LC unit is empty.	<ul style="list-style-type: none"> <li>- Setting of "VOL" switch different than attached LC unit</li> <li>- Partly filled LC unit was replaced by an almost empty LC unit</li> </ul>	Replace with full LC unit
perma STAR CONTROL TIME signals "system malfunctions" (red LED)	<ul style="list-style-type: none"> <li>- Clogged tube and/or connection parts</li> <li>- Counter pressure too high</li> </ul>	Clean tube and connecting parts, then shut off and restart perma STAR CONTROL TIME (refer to chapter 7.3.2)
perma STAR CONTROL TIME discharges too fast	<ul style="list-style-type: none"> <li>- Wrong position of "VOL" switch</li> <li>- Wrong position of "TIME" switch</li> </ul>	Correct switch setting (refer to chapter 7.3.2)
perma STAR CONTROL TIME signals "end of discharge" (red and green LED), although the unit is not empty	<ul style="list-style-type: none"> <li>- Setting of "VOL" switch different than attached LC unit</li> <li>- Almost empty LC unit was replaced by a partly filled LC unit</li> <li>- Reset-peg was not pushed down during assembly</li> </ul>	<p>Replace with full LC unit</p> <p>Move drive unit a few teeth so that reset-peg is pushed down.</p>
perma STAR CONTROL TIME does not discharge the correct amount	<ul style="list-style-type: none"> <li>- Changing of the Dip-switch-setting was done incorrectly</li> </ul>	Refer to chapter 7.3.2

## 9 DISPOSAL



Help us in protecting the environment and saving resources by recycling valuable raw material. Please follow the individual waste disposal regulations in your country.

## 10 ACCESSORIES FOR perma STAR CONTROL TIME



Accessories and replacement parts must meet the technical requirements. This can be guaranteed by using original parts from perma-tec.

### 10.1 Accessories

- ◆ Cable 5 m part no. 26 004 001  
10 m part no. 26 004 004
- ◆ STAR support flange G1/4o x G1/4i (brass/plastic) part no. 26 001 620  
STAR support flange 1/4" NPT (brass/plastic) part no. 26 001 621
- ◆ Clip (plastic) part no. 26 001 105
- ◆ Bracket (stainless steel) part no. 26 00012 150 with insert for bracket G1/4o x G1/4i (brass) part no. 26 0011 151 or oil retaining valve up to +60 °C (brass with plastic-valve) part no. 26 0011 810
- ◆ 400 g grease cartridge or oil container
- ◆ Lubrication Maintenance Plan
- ◆ Additional accessories on request

### 10.2 Replacement parts

- ◆ LC unit (thread R1/4) in size:
  - S60 (60 cm<sup>3</sup>)
  - M120 (120 cm<sup>3</sup>)
  - L250 (250 cm<sup>3</sup>)
- ◆ Drive unit
- ◆ Cover for drive unit (part no. 72 102 002)

## 11 SERVICE

Please contact your local supplier for availability and cost of the following:

- ◆ Returning of the empty lubricator for environmentally safe recycling or disposal.
- or:
- ◆ exchange the LC unit
  - ◆ setting the desired discharge amount

## 12.1 Suggestion for PLC connection with one output signal

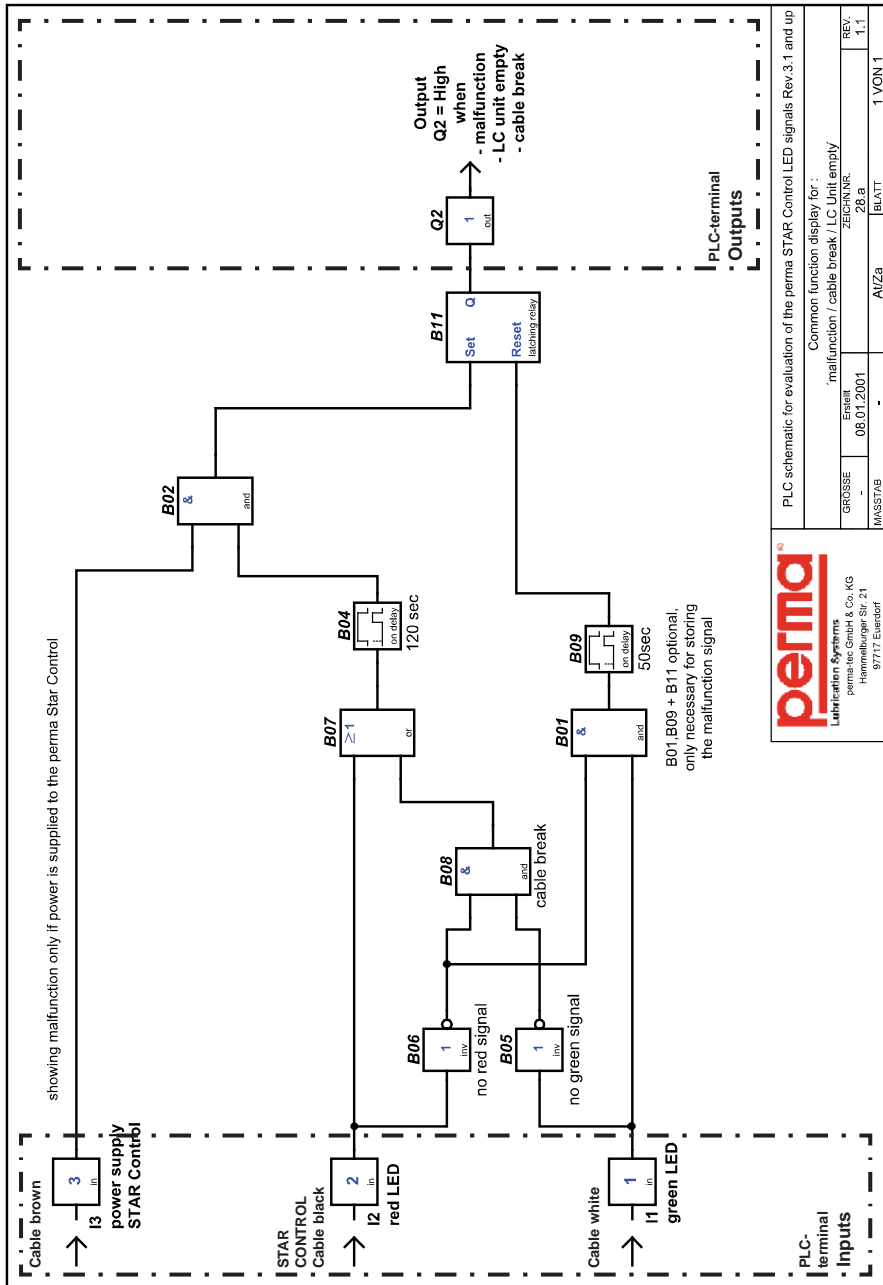

**perma**<sup>®</sup>  
Lubrication Systems  
Perma-tec GmbH & Co. KG  
Hammelburger Str. 21  
97171 Euerdorf

PLC schematic for evaluation of the perma STAR Control LED signals Rev.3.1 and up

GROSSE		Exakt	ZEICHNR.	REV.
MASSTAB		08.01.2001	28.a	1.1
ANZa			BLATT	1 VON 1



## 12.2 Suggestion for PLC connection with two output signals

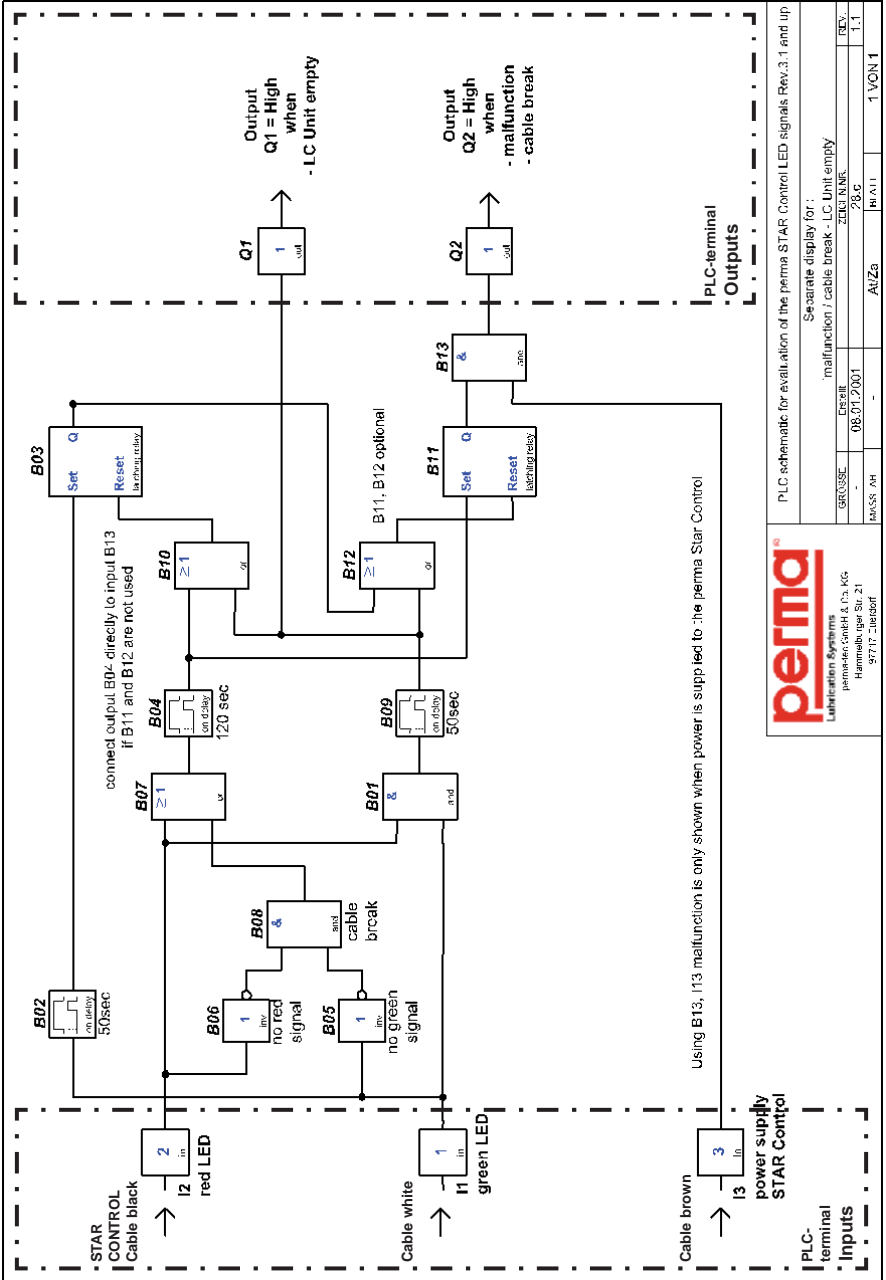

### 12.3 Suggestion for PLC connection with three output signals

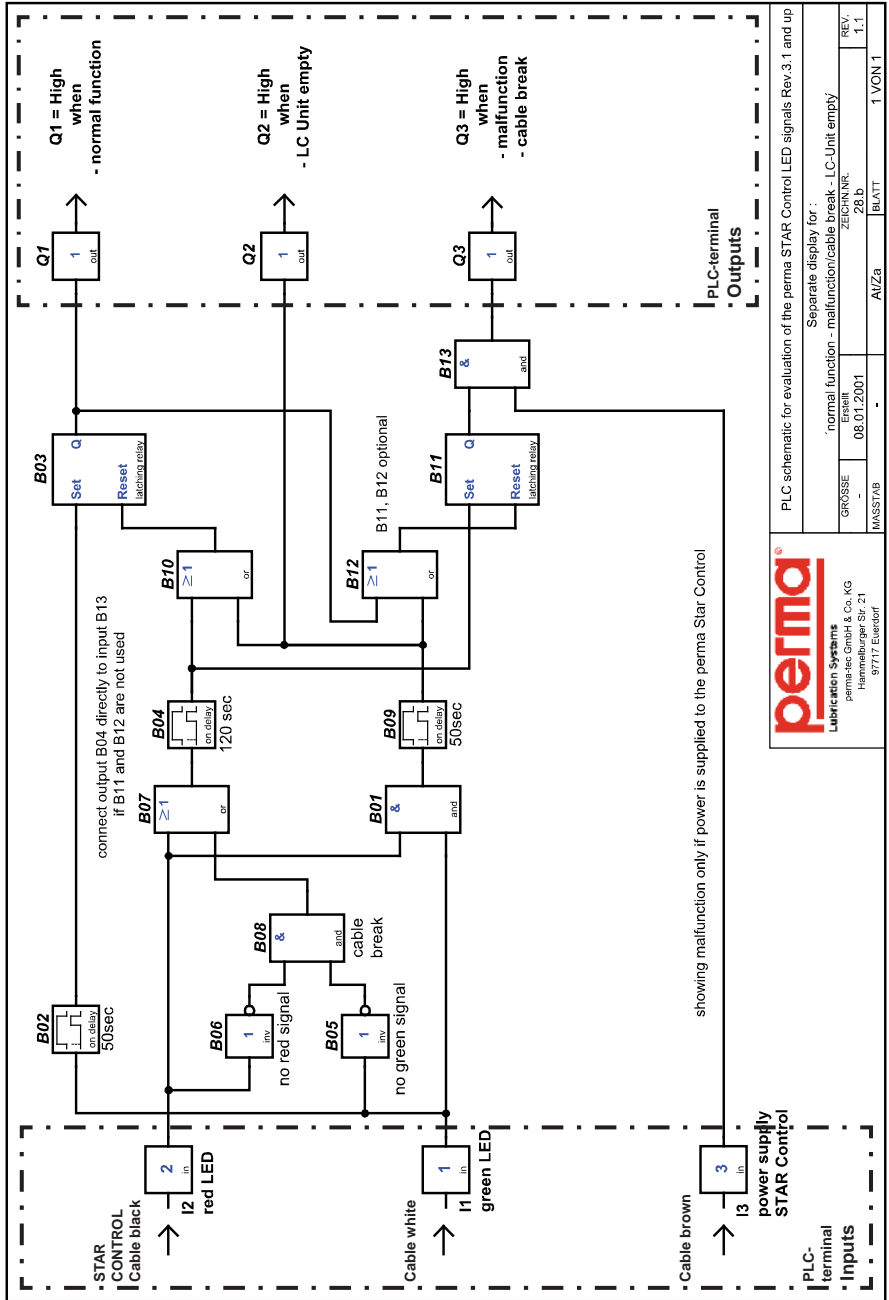







PLC schematic for evaluation of the perma STAR Control LED signals Rev.3.1 and up

Separate display for :

GROSSE	Erseilt	ZEICHN.NR.	REV.
-	08.01.2001	28.b	1.1
MASSTAB	-	A1/Za	1 VON 1
			BLATT

perma<sup>®</sup>  
Lubrication Systems  
perma-tec GmbH & Co. KG  
Hammelfuriger Str. 21  
97717 Everdorf

 EG-Konformitäts- erklärung	 EC Declaration of Conformity	 Déclaration CE de conformité	 Declaración de conformidad CE	 Dichiarazione di conformità CE
perma-tec GmbH & Co. KG Hammelburger Straße 21 97717 EUERDORF   GERMANY				
In der Gemeinschaft ansässige Person, die bevollmächtigt ist, die relevanten technischen Unter- lagen zusammen- zustellen:	Person residing within the Com- munity authorised to compile the relevant technical documentation:	Personne établie dans la Communauté autorisée à établir le dossier technique pertinent:	Persona con residencia en la Comunidad que está autorizada a crear los pertinentes documentos técnicos:	Persona residente nella Comunità autorizzata a raccogliere la documentazione tecnica necessaria:
(siehe Hersteller- anschrift)	(see manufacturer address)	Egon Eisenbacher (cf. l'adresse de fabricant)	(ver dirección del productor)	(vedere indirizzo del fabbricante)
<b>Produkt- bezeichnung:</b>	<b>Product description:</b>	<b>Désignation:</b>	<b>Tipo de producto:</b>	<b>Descrizione del prodotto:</b>
Automatisches Schmiersysteml	Automatic lubrication system	Système de lubrifi- cation automatique	Sistema automático de lubricación	Sistema di lubrifi- cazione automatica
<b>Produktname:</b>	<b>Product name:</b>	<b>Nom du produit:</b>	<b>Denominación producto:</b>	<b>Nome del prodotto:</b>
<b>STAR CONTROL TIME</b>				
<b>Type:</b>	<b>Type:</b>	<b>Type:</b>	<b>Tipo:</b>	<b>Tipo:</b>
<b>S60, M120, L250</b>				
<b>Produktidenti- fikationsnummer:</b>	<b>Product identi- fication number:</b>	<b>Número d'identi- fication produit:</b>	<b>Número de identi- ficación del producto:</b>	<b>Codice identifica- tivo del prodotto:</b>
<b>ST-E1</b>				
Es wird ausdrück- lich erklärt, dass die Maschine allen einschlägigen Bestimmungen der folgenden EU Richtlinien entspricht:	It is expressly declared that the machinery fulfils all relevant provisions of the following EU Directives:	Une déclaration pré- cisant expressément que la machine satis- fait à l'ensemble des dispositions perti- nentes des directives CE suivantes:	Se declara expresa- mente que la máqui- na satisface todas las disposiciones pertinentes de las siguientes directivas CE:	Si dichiara espressamente che il prodotto è conforme alle disposizioni conte- nute nelle seguenti direttive CE:
<b>2006/42/EG 2004/108/EG</b>	<b>2006/42/EC 2004/108/EC</b>	<b>2006/42/CE 2004/108/CE</b>	<b>2006/42/CE 2004/108/CE</b>	<b>2006/42/CE 2004/108/CE</b>
Folgende harmoni- sierte Normen wurden angewandt:	The following har- monised standards were applied:	Les normes associées suivantes ont été utilisées:	Se han aplicado las siguientes normas de armonización:	Sono state recepite le seguenti norme di standardizzazione:
<b>EN ISO 12100:2010, EN 61000-6-2:2005, EN 61000-6-4:2007+A1:2011</b>				

Euerdorf, 30 July 2012

  
 Walter Graf, Managing Director

  
 Egon Eisenbacher, Technical management

**perma-tec GmbH & Co. KG**

Hammelburger Str. 21  
97717 EUERDORF

GERMANY

Tel: +49 9704 609 0

Fax: +49 9704 609 50

[info@perma-tec.com](mailto:info@perma-tec.com)

[www.perma-tec.com](http://www.perma-tec.com)